

**1 UNIVERSAL RELAY VOLTAGE TRIGGERED LOAD CONTROLLER “BSD Model”**  
**MODEL 1URVTLC-1224-BSD 12V/24V (Board Version 1.0.XX)**

**“With Out Delays” or “No Delays” (If you need delays see the 1URVTLC-1224-B)**

**For both EMR’s (ElectroMechanical Relays)**

**and SSR’s (Solid State Relays)**

**(Manual Version 1.0.00)**

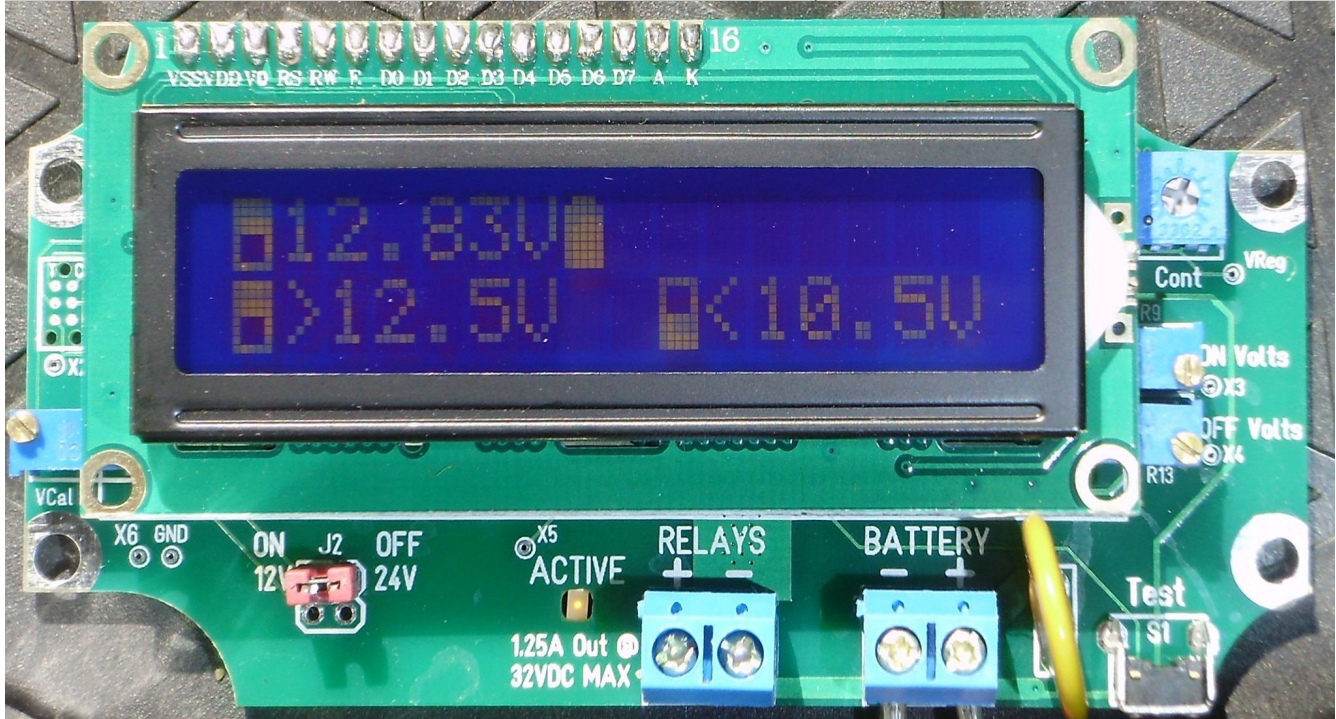

**READ ALL INSTRUCTIONS CAREFULLY FIRST!!**

**IF YOU HAVE ANY DOUBTS ABOUT YOUR ABILITIES TO PUT TOGETHER A SYSTEM OF THIS TYPE THEN DON'T DO IT!! FIND AND/OR HIRE SOMEONE QUALIFIED WHO CAN!!**

**ATTENTION: USE ESD PRECAUTIONS FOR HANDLING ELECTRO-STATIC SENSITIVE DEVICES.**

**WARNING!**

**If attempting to switch PV/Solar panels directly and not dumping the battery to a load. You'll need to connect the “PV Positive” to battery Positive and “SWITCH the PV Negative”. Switching the “PV Positive” can/will produce high energy pulses at PV Open Circuit Voltages that can/will destroy the controller and Solid State Relay/s! This will VOID your warranty as this controller and most DC SSR's control circuits are rated at 32VDC MAX!**

## FEATURES

- ✔ The ability to Directly Switch up to 8 Electromechanical or 50+ DC-DC Solid State Relays
- ✔ 12V Mode Individual Adjustable On-Off Set-points (*10.5 to 15.5 Volts in 0.1V increments*)
- ✔ 24V Mode Individual Adjustable On-Off Set-points (*21 to 31Volts in 0.1V increments*)
- ✔ Extremely Low Power Consumption ( $\leq 30\text{ma max}$ )
- ✔ 2-Line User Friendly Backlit LCD Display
- ✔ Accurate Volt Meter/Tracking (*2 decimal points resolution  $\pm 0.1\%$  +3 digits or less typically*)
- ✔ 32Mhz 8-Bit Microcontroller
- ✔ Latest SMT (*Surface Mount Technology*) for Compact Size and Improved Performance
- ✔ Self Resetting Fuse
- ✔ Relay Powered/Active LED Indicator
- ✔ Test Button
- ✔ Reverse Polarity Protection
- ✔ Over Voltage Protection
- ✔ Over Current Protection
- ✔ Transient/Lightning/Surge Protection

## BASIC OPERATING PRINCIPLE

Basic operation principle is quite simple. The Microcontroller constantly monitors the battery voltage. When battery voltage meets the specific criteria, the Microcontroller activates or deactivates the LED's and external relays.

*(Example 2– “(ON) >13.0V 40S”. When the Battery Voltage Rises Above 13.0V Then the controller will turn ON the Relay (Output).*

*(Example 1– “(OFF) <13.0V”. When the Battery Voltage Drops Below 13.0V Then the controller will turn OFF the Relay (Output).*

## DESCRIPTION

These “Universal Relay” Voltage Triggered Load Controllers were brought about by there being no low cost user friendly expandable Voltage Triggered Load Controllers on the market at this time with a User Friendly LCD readout.

The “Universal Relay” Voltage Triggered Load Controllers are low cost, Microprocessor controlled Diversion Load Switching type controllers designed for the System Designer or **DIY (Do It Yourself)**. It is designed to switch up to 8 conventional automotive style electromechanical relays (*EMR*) directly with up to 1.25A @ 40C total coil current draw with up to 320A power handling capability. Also, it is theoretically able to directly switch up to 50 SSR's at 25ma each (*untested*). If using just 40 amp SSR's that adds up to a potential 2000A (*5000A using 100 amp SSR's*) power handling capability.

To keep cost down, this controller was designed for the System Designer or **DIY (Do It Yourself)** and is the **BOARD ONLY** and does **not** include an enclosure. It can be mounted directly on a wall in an area protected from the environment or in an **Optional** or **user supplied** enclosure.

I will try to keep this manual as simple and straight forward as possible. To keep cost down and prevent unnecessary waste this manual is available in PDF format only (just printout what you need). The latest version of this manual is **Free** for from [WindAndSunPower.com](http://WindAndSunPower.com). Jeff

## PCB Legend

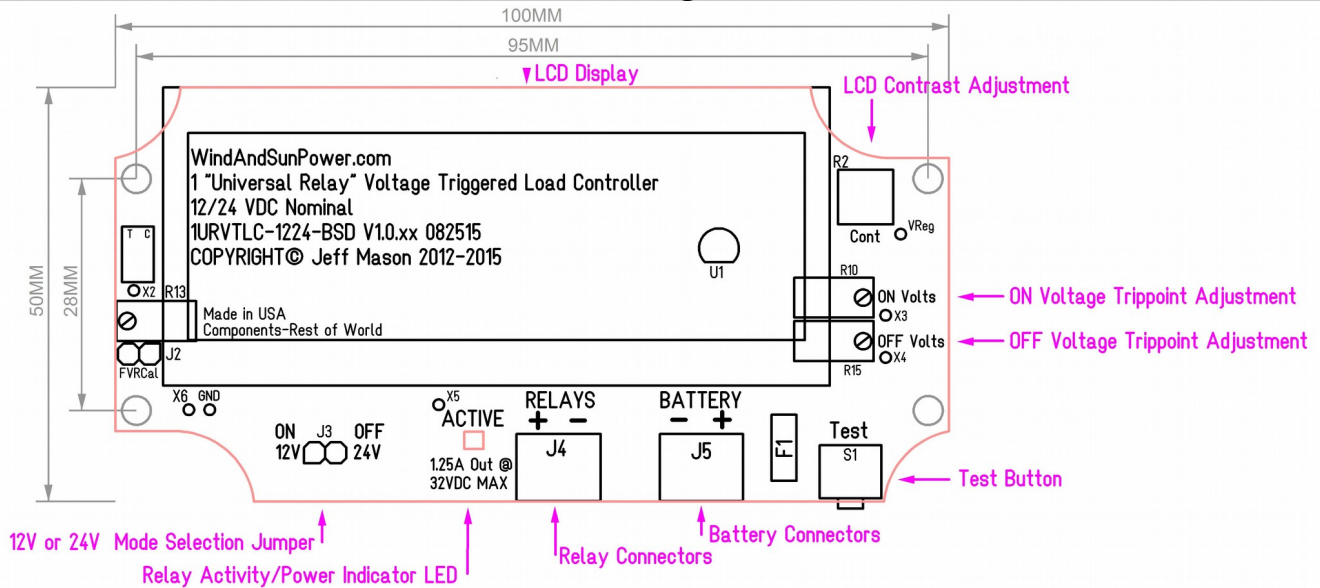

Diagram 3.

1. **LCD Display** – LCD readout for battery voltage, status, functions, etc.
2. **LCD Contrast Adjustment** – Used to adjust the LCD displays contrast for best viewing. If needed, slowly turn clockwise or counterclockwise for best readability.
3. **12V or 24V Mode Selection Jumper** – Selects 12V or 24V nominal operating mode.
  - On= 12V. (Default)
  - Off = 24v.
4. **On Volt and Off Volt Adjustments** – Used to set the On and Off Voltage Set/Trip Points from 10.5 volts to 15.5 volts in 0.1V increments in 12Volt Mode. Or, used to set the On and Off Voltage Set/Trip Points from 21.0 volts to 31.0 volts in 0.1V increments in 24 Volt Mode. Turn clockwise to raise or counterclockwise to lower the Voltage Set/Trip Point until you have your desired stable setting. *(Note – If ON Volts setting is the same as OFF Volts setting Then OFF Volts defaults to 0.01V less than ON Volts.)*
5. **Battery Connectors** – Positive and Negative 12V/24V battery power/sense connectors. Connect to 12 or 24 volt batteries **ONLY!** **DO NOT** connect directly to a High Voltage power source (*Solar, Wind and/or Hydro generators outputs!*)
6. **Relay Active Indicator** – LED indicates if the relay output is Active (*has power*).
7. **Relay Connector** – Positive and Negative battery output connectors to external electromechanical (EMR) or solid state relays (SSR).
8. **Test Button** – Pressing the Test button simulates a high battery voltage condition. Holding the Test/EQ button will cause it to scroll through menu items every 2 seconds next to the battery voltage readout. Release the Test button when the menu item you desire appears to select it.
  - **TEST** – Alternately activates/deactivates the relay/s and flash Activity LEDS 4 times.
  - **Info** – Reboots the system displaying version and other information.

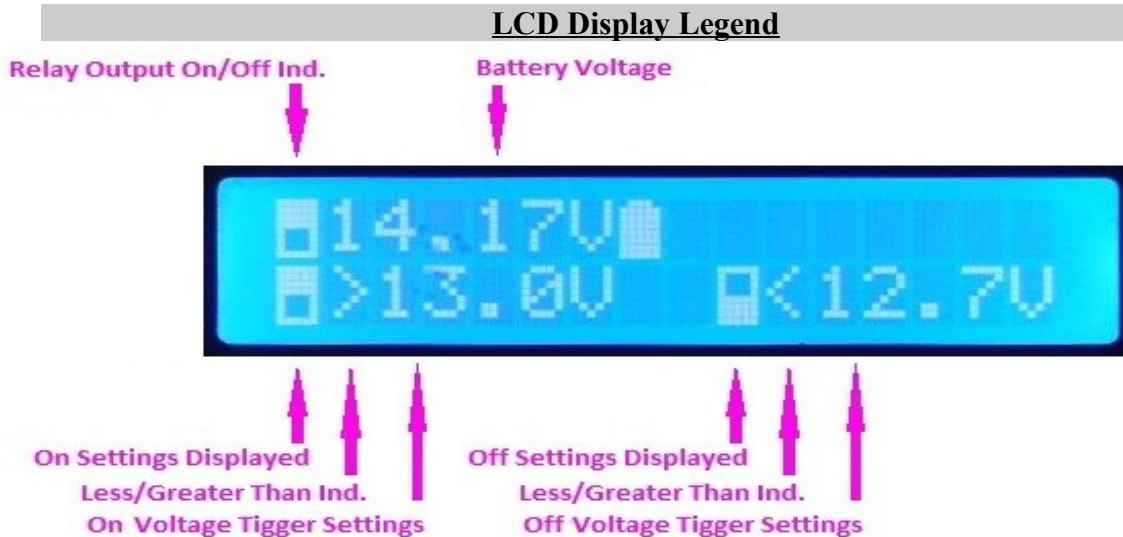

Diagram 4.

1. **Relay Output On/Off Indicator** – Indicates whether relay output is On or Off. (Switch style, On-Solid block is in the Top position, Off-Solid block is in the Bottom position).
2. **Battery Voltage** – Displays current Battery Voltage.
3. **On or Off Settings Displayed** – Indicates whether the On or Off settings is currently being displayed on line 2.
4. **Less Than – Greater Than Indicator** – Indicates whether the trip-point is at Less Than or Greater Than the Voltage Trigger Settings. *(Example – “(OFF) <13.0V”. When the Battery Voltage Drops Below 13.0V Then the controller will turn OFF the Relay (Output).*
5. **Voltage Trigger Setting** – Displays the ON or OFF Voltage trigger setting.

## MOUNTING

To keep cost down, this controller was designed for the System Designer or **DIY (Do It Yourself)** and is the board only and does not include an enclosure. It can be mounted directly on a wall in an area protected from the environment or in an **optional** or **user** supplied enclosure.

This Board has been designed to fit in the following inexpensive [BUD Industries NEMA Enclosures with molded external mounting brackets](#):

[\*\*\*PN-1321-C-MB Poly Carbonate/Light Gray Body with Clear Cover.\*\*\*](#)

Will fit the following also:

PN-1321-DG-MB ABS/Dark Gray Body and Cover.

PN-1321-MB Polycarbonate/Light Gray Body and Cover.

The board does not generate much heat but it does generate some and the more relays, the more heat. Because heat sinking is incorporated into the board design and to prevent shorting, the board should be mounted at least ¼ inch off the surface using some sort of standoffs if not mounted in one of the above enclosures.

With EMR's the controller and the relays can usually be mounted in the same enclosure if there is adequate room because under normal operating conditions the EMR's **usually** generate little heat. However if you are using SSR's they can generate a lot of heat and the SSR heat-sink assembly should be mounted in a well ventilated area on a metal surface in free air preferably or in a well ventilated metal inclosure. The same goes for power resistors.

## WIRING

If you look at the wiring diagrams you can see the wiring is pretty straight forward. You should use pairs of 22 to 16 gauge AWG wire between the controller and batteries, also from the controller to the relays. Keeping distances between components close as possible for maximum efficiency and accuracy. **But NOT in the same enclosure with the Batteries as arcing from the relays can ignite the Hydrogen gasses produced by the batteries and explode!** Also the corrosive gasses can damage the electronics. The loads, fuses and wires from the relays to the loads and power sources to the batteries will need to be calculated for your systems maximum potential output.

Min. Copper Gauge	Max. Amperage	Min. Copper Gauge	Max. Amperage
18AWG	7.5A	8AWG	45A
16AWG	10A	6AWG	60A
14AWG	15A	4AWG	80A
12AWG	20A	2AWG	100A
10AWG	30A	1AWG	125A

**Note: Relays need to be connected *BEFORE* power is applied to the controller!**

## Battery State Of Charge Gauge

Based On Trojan Batteries FLA SOC chart. Gauge is divided into 20% increments using the “<” Less Than and “>” Greater Than symbols. For accurate voltage SOC readings, batteries must remain idle (no charging/discharging) at least 6 hours but preferably up to 24 hours.

### State of Charge as Related to Specific Gravity and Open Circuit Voltage

Percentage of Charge	Specific Gravity Corrected To	Open-Circuit Voltage					
		Cell	6v	12v	24v	36v	48v
100	1.277	2.122	6.37	12.73	25.46	38.20	50.93
90	1.258	2.103	6.31	12.62	25.24	37.85	50.47
80	1.238	2.083	6.25	12.50	25.00	37.49	49.99
70	1.217	2.062	6.19	12.37	24.74	37.12	49.49
60	1.195	2.04	6.12	12.27	24.48	36.72	48.96
50	1.172	2.017	6.02	12.10	24.20	36.31	48.41
40	1.148	1.993	5.98	11.89	23.92	35.87	47.83
30	1.124	1.969	5.91	11.81	23.63	35.44	47.26
20	1.098	1.943	5.83	11.66	23.32	34.97	46.63
10	1.073	1.918	5.75	11.51	23.02	34.52	46.03

## RELAYS

This was designed to use up to 8 Automotive style EMR's (*the ones you can find in auto parts stores for about 3 to 5 dollars each*) or up to 50 DC-DC SSR's. Multiple relays need to be wired in parallel. This can be used with other types of NON-LATCHING EMR's with nominal **coil ratings of 12VDC or 24VDC (depending on use with 12V or 24V mode) 1.25A max and the contacts MUST be rated above your battery bank voltage.** You will need to test them out to see if they will perform suitably. Dependent upon load, batteries and generator output, this controller can regulate the battery voltage to

within  $\pm 0.2\% + 0.03V$  or less on the average with SSR's. Whereas using EMR's with On/Off type Diversion controllers, battery voltage can fluctuate a volt or more. This was designed for use with **DC-DC SSR's Only!** SSR's need adequate heat-sinking as they can get **HOT!**

Diagrams 1. and 2. below are some examples of SSR Heat Sinks.

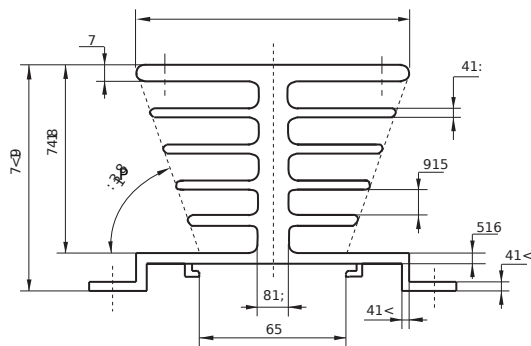
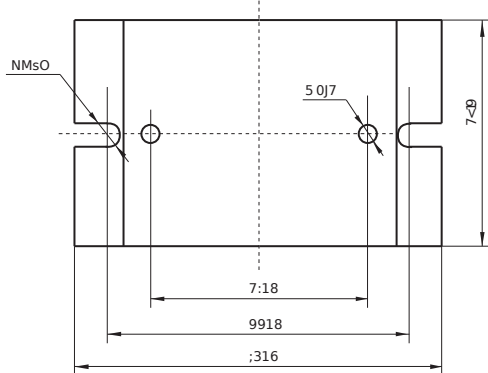

Diagram 1.

**15A SSR Heatsink Example**  
Approximately 2" L x 2.5" W x 2" H

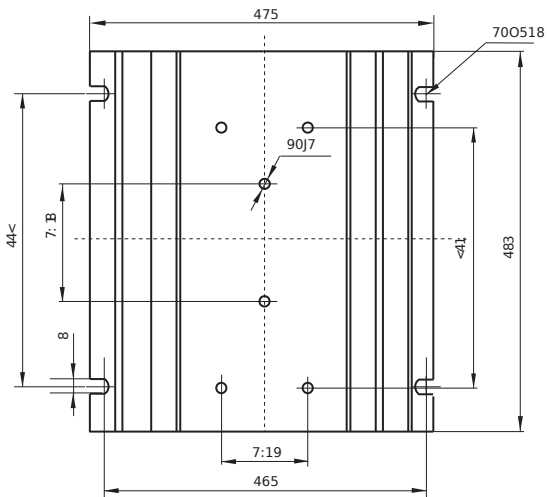
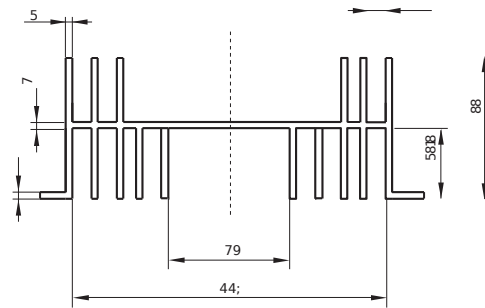

Diagram 2.

**40A-80A SSR Heatsink Example**  
Approximately 6" L x 5.5" W x 2" H

**12V mode *REQUIRES* EMR's with 12V nominal coils!**

**24V mode *REQUIRES* EMR's with 24V nominal coils!**

**Relays should be connected *BEFORE* power is applied to the controller!**

Also some SSR Manufacturers suggest using their SSR's at less than 70% of it's rated power (40A=28A Max).

Here are some inexpensive Chinese **DC-DC** SSR's tested:

**Mager MGR-1 DD220D80 GOOD** – Tested W/ 75A@15V Load,  $\leq 50\text{HZ}$  (eBay, AliExpress)

**Mager MGR-1 DD220D60 GOOD** – Tested W/ 55A@15V Load  $\leq 50\text{HZ}$  (eBay, AliExpress)

**Mager MGR-1 DD220D40 GOOD** – Tested W/ 39A@15V Load,  $\leq 50\text{HZ}$  (eBay) (I've tested/used/using several of these for several years now and they're all still working)

**Mager MGR-1 DD220D25 GOOD** – Tested W/ 20A@15V Load,  $\leq 50\text{HZ}$  (eBay, AliExpress)

**Mager MGR-1 DD220D10 GOOD** – Tested W/ 8A@15V Load,  $\leq 50\text{HZ}$  (eBay, AliExpress)

**SMUNGLE SG D2240D Failed** – Tested W/ 35.75A@14.3V Load,  $< 50\text{HZ}$  (eBay) Latched closed

**FOTEK SSR – 40 DD Failed** – Tested W/ 35.75A@14.3V Load,  $< 50\text{HZ}$  (eBay) Latched Open until it cooled off (Over Temperature Protection?)

**FOTEK HPR-40 DD Failed** – Tested W/ 35.75A@14.3V Load,  $< 50\text{HZ}$  (eBay) Short to ground

**FOTEK SSR-80 DD Failed** – Tested W/ 71.5A@14.3V Load, <50HZ (Aliexpress) Latched closed  
 Needless to say, I don't recommend, nor am I probably going to test any more FOTEK's from eBay or Aliexpress as these are all probably Chinese counterfeits and not the real ones made in Taiwan.

I also tested one of the so called 12V **440 Amp 6 Terminal Solenoids** (Sold as Relays). It's coil had an on current of less than 700ma and worked fine with my controllers. Use **CAUTION** as different manufactures may differ in specs on these, you should measure the coils ON current draw to assure it's less than 1 Amp. Also if using in a 24V system, be sure to get one with a 24V coil as these output the battery voltage to activate the relays.

<b>Troubleshooting</b>		
<b>Alarm Type</b>	<b>Possible Causes</b>	<b>Possible Solutions</b>
<b>Yellow Activity LED is <u>On Constant</u> And Relay is <u>OFF</u></b>	<ol style="list-style-type: none"> <li>1. Loose/Bad connection</li> <li>2. Latched/Bad relay</li> <li>3. Circuit MOSFET/s blown</li> </ol>	<ol style="list-style-type: none"> <li>1. Check/tighten all connections</li> <li>2. Test and replace relay if needed</li> <li>3. Contact WindAndSunPower.com for Repair/Replacement</li> </ol>
<b>Yellow Activity LED is <u>OFF</u> And Relay is <u>On Constant</u></b>	<ol style="list-style-type: none"> <li>1. Shorted connection</li> <li>2. Latched/Bad relay</li> </ol>	<ol style="list-style-type: none"> <li>1. Check/tighten all connections</li> <li>2. Test and replace relay if needed</li> </ol>

# Wiring Diagram 1. SOLID STATE RELAY (SSR)

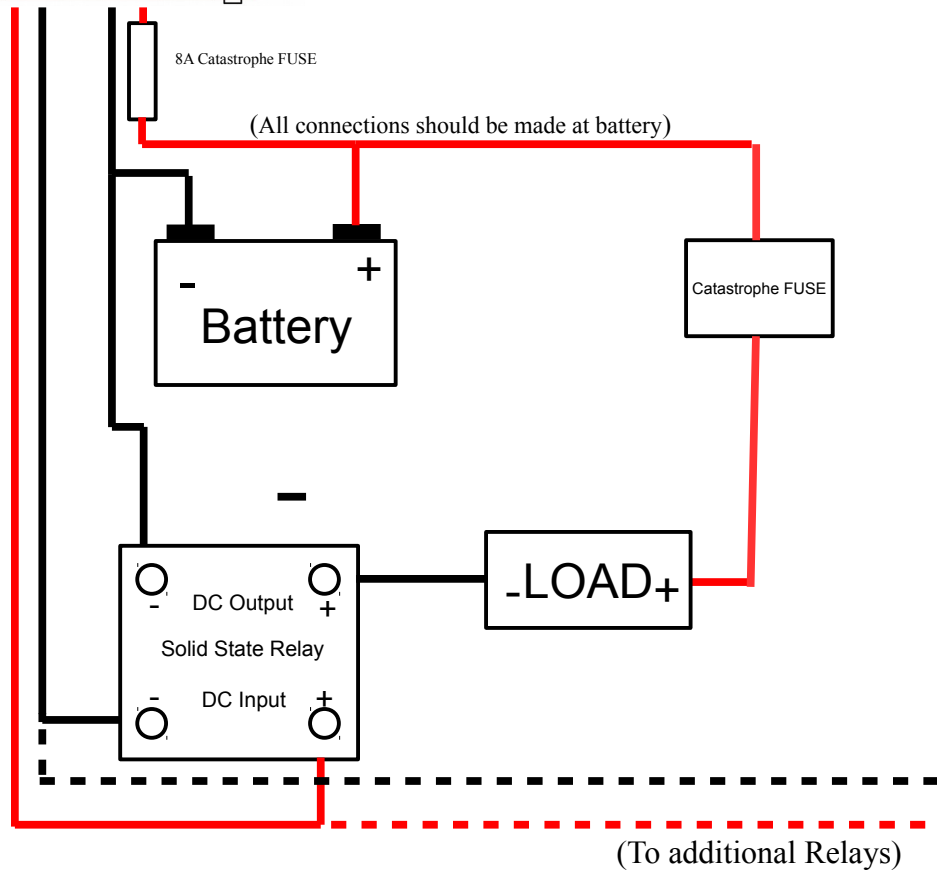
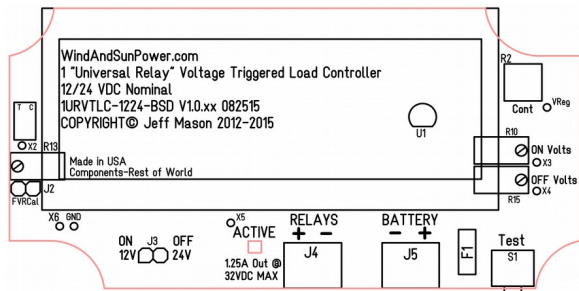
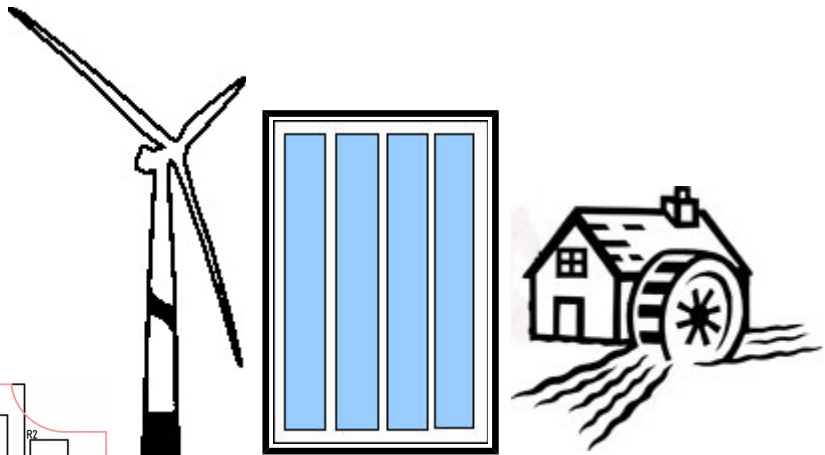



**Wiring Diagram 2. ELECTROMECHANICAL RELAY (EMR)**

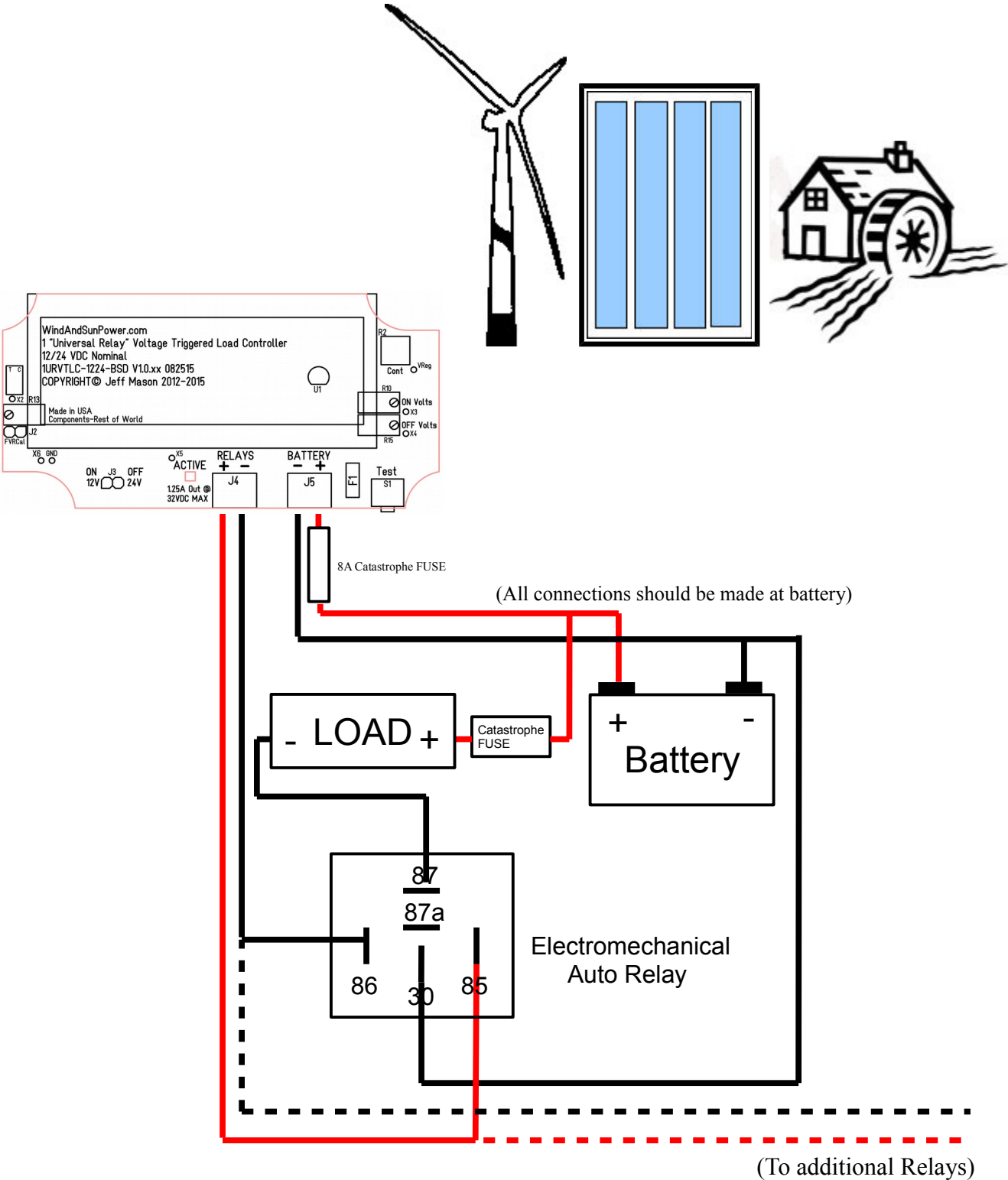

## SPECIFICATIONS

<b>Min. Operating Volts</b>	7 VDC	<b>Max. Operating Volts Volts Max.</b>	32VDC 35VDC
<b>Nominal Operation Voltage</b>	12VDC or 24VDC	<b>Relay Connectors Output Voltage</b>	= Battery Voltage
<b>Max. Power Used by Controller</b>	≤ 30ma max	<b>Power Sunk @ Ambient Temp.</b>	-1.25A Max. @ 40C -1.00A Max. @ 60C
<b>12V Voltage Adjustment Range</b>	10.5 to 15.5 Volts in 0.1V increments	<b>24V Voltage Adjustment Range</b>	21.0 to 31.0 Volts in 0.1V increments
<b>Seconds Adjustment</b>	None – See 1URVTLC- 1224-B if you need delays.	<b>Minutes Adjustment</b>	None – See 1URVTLC- 1224-B if you need delays.
<b>LCD Accuracy Battery Voltage</b>	<i>2 decimal points resolution ±0.3% +3 digits or less @ 23C</i>	<b>Internal Battery Voltage Tracking</b>	±0.3% +3 <i>digits</i> or less @ 23C
<b>Automotive style ElectroMechanical Relays</b>	1 up to 8 12 or 24VDC Coil @ 160ma Per Coil	<b>Solid State Relays 2-Stage &amp; Equal</b>	DC-DC 1 up to 50? ≤10ms On or less ≤10ms Off or less
<b>Operating Temp. Storage Temp.</b>	-20°C to 60°C -50°C to 150°C	<b>Dimensions</b>	100 mm x 50 mm (3.93 in. x 1.96 in.)

Specifications subject to change without notice.

**Made in USA-Components Made in Rest of World**

### WARRANTY:

[WindAndSunPower.com](http://WindAndSunPower.com). Model 1URVTLC-1224-BSD is warranted to be free of defects in material and workmanship for three years from the date of purchase. Failure to provide correct installation, operation or care for this product, in accordance with the instruction manual, will void the warranty. Product liability shall be limited to repair or replacement at the discretion of the manufacturer. The manufacturer is not responsible for the labor or other charges necessitated by the removal, transportation, or re-installation of any defective product. Warranty does not cover damage due to, mishandling, abusive conditions, lightning or exposure to weather. No specific claim of merchantability shall be assumed or implied beyond what is printed in this manual. No liability shall exist from circumstances arising from the inability to use this product, or it's inappropriateness for any specific purpose. In all cases it shall be the responsibility of the customer to insure a safe installation in compliance with local, state and national electrical codes.

### RETURN PROCEDURE:

To return a model 1URVTLC-1224-B for warranty service please contact [WindAndSunPower.com](http://WindAndSunPower.com) for return authorization and shipping instructions. Provide the following information shipped with the controller. Name/Company name, return address, daytime phone number, detailed description of failure, copy of sales receipt. Include \$4.00 for return shipping

COPYRIGHT© 2010-2015 Jeff Mason [WindAndSunPower.com](http://WindAndSunPower.com) All Rights Reserved